

LETTERING TO BE
CAST FLUSH WITH TOP
OF LID. POSITION
AS SHOWN

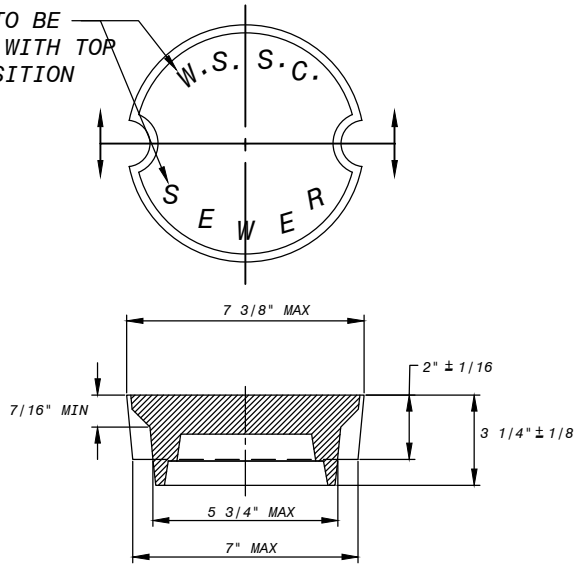

COVER

WEIGHT : 12 1/2 LBS MIN.

- SECTION TO BE GRAY IRON CASTING, ASTM A-48 CLASS NO. 25 MIN.
- ALL CASTINGS ARE TO BE CLEANED BY AN APPROVED PROCESS AND COATED WITH AN APPROVED SOLVENT-BASED ASPHALT PAINT.

APPLICABLE STOCK NO.
4881 -9006 -7

<p>WASHINGTON SUBURBAN SANITARY COMMISSION</p>	<p>REVISIONS: APPROVED: <u>May 3, 2021 9:23 PM EDT</u></p> <p>DocuSigned by: <i>Jaime Garcia</i></p> <p><small>B7DBE23469C84BD MATERIALS MANAGEMENT DIVISION MANAGER</small></p>	<p>PROCUREMENT AND MANUFACTURING DETAIL ADJUSTABLE VALVE BOX COVER MARKED SEWER (ALSO USED AS COVER FOR 4" SEWER CLEANOUT FRAME)</p>	<p>P&M 1.2</p>
--	--	---	--------------------------------------